



Installation Notes

- When used outdoors, the manual pull station must also be rated for outdoor use.
- UL Listing does not permit connection of horn relay contacts to fire alarm or life safety devices.
- According to UL Listing, models powered from an external power source cannot be supplied from the fire alarm panel.
- When properly installed, the operation of this cover will not interfere with the function of your life safety system.
- Horn operation and performance must be tested annually. Battery replacement is recommended annually dependent on usage and battery expiration date.
- Ensure the service pin is properly inserted in the service pin receptor to silence horn while performing installation or servicing horn.
- If mounting to an uneven surface, a backplate (STI-1314) is recommended to help ensure proper sealing to mounting surface.
- The backplate may be drilled if wire access or screw mounting holes are needed.

Installation Instructions

1. Center the pull station to the Universal Stopper with the help of the dimensions in Fig. 1. Open cover and use the mounting frame or optional backplate to mark the mounting hole locations as in Fig. 1. **Be sure the entire cover travel will not interfere with operation of the pull station or other safety system equipment when installed.**

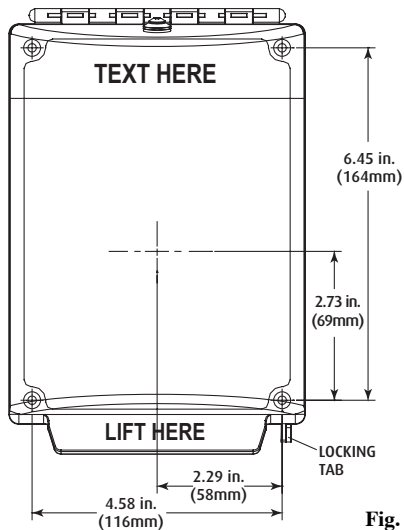

Fig. 1

2. If drilling into wood, four #6 x 1 ¼" screws (provided) should be used without anchors and the mounting holes should be drilled 7/64" diameter to a depth of 1 ¼". If drilling into masonry or drywall (sheet rock), the wall anchors (provided) should be used and the mounting holes drilled 3/16" diameter to a depth of 1 ¼".
3. Refer to Fig. 2, 3 and 4 for illustrations of the different mounting configurations (BACKBOX, FLUSH, SURFACE). For additional seal reliability, a silicone sealant may be applied between optional backplate and wall.
4. (For the BACKBOX mounting option only) If routing conduit from above, run the conduit through the hole in the top of the housing.
5. (For the BACKBOX mounting option only) If routing from below, use a flat head screwdriver or coin to remove the NPT Plug. Then knock out a hole in the bottom and run the conduit up through the bottom of the housing. Apply thread sealant. Screw the NPT plug back into the threaded top of the housing.

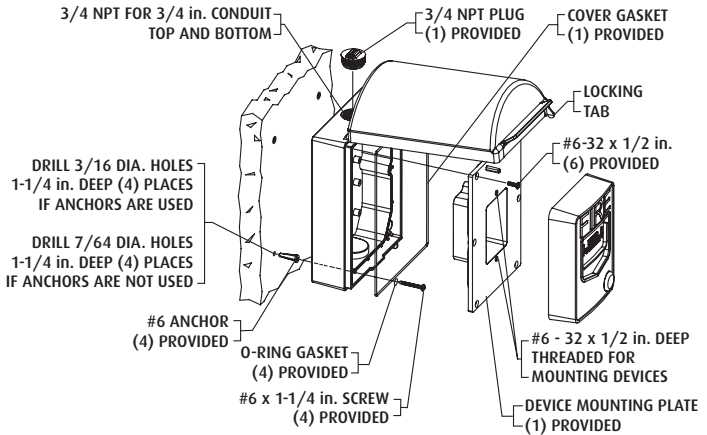

Fig. 2 - BACKBOX MOUNTING OPTION

6. (For the SURFACE mounting option only) Note that the inserts fit flush to the housing only in one orientation (see Fig. 4). Prior to applying either of the Conduit Weather Gaskets, ensure proper orientation and fit of the desired inserts from the top or the bottom of the housing.
7. (For the SURFACE mounting option only) After noting the proper insert orientation, fit the appropriate Conduit Weather Gasket size (1/2" or 3/4") to the conduit. Then fit the gasket to the Conduit Insert or directly to the housing knock-out. Repeat this step with the appropriate installation on the opposite. **For additional seal reliability, a bead of silicone may be applied to the conduit fitting.**
8. (For the SURFACE mounting option only) Use the 3" gaskets (provided) to complete the seal across the top and bottom insert locations. Overlap 1/8" of the existing Mounting Gasket on the Universal Stopper body, run the cord into the preformed channel until it overlaps 1/8" of the opposing Mounting Gasket. **The 3" gasket may need to be trimmed for a proper fit and seal.**
9. Align mounting holes in frame to the screw holes made in the wall. If applicable, ensure a proper seal is made between the wall and the Mounting Gasket embedded on the Universal Stopper. If needed, use optional STI Backplate (STI-1314).
10. (For the BACKBOX mounting option only) Insert the #6 x 1 ¼" Phillips Pan Head Screws (provided) into the #6 O-rings STI-01317 (provided) to seal the Backbox mounting holes.
11. Put the #6 x 1 ¼" Phillips Pan Head Screws (provided) through the frame holes into the drilled screw holes and tighten to mounting surface.

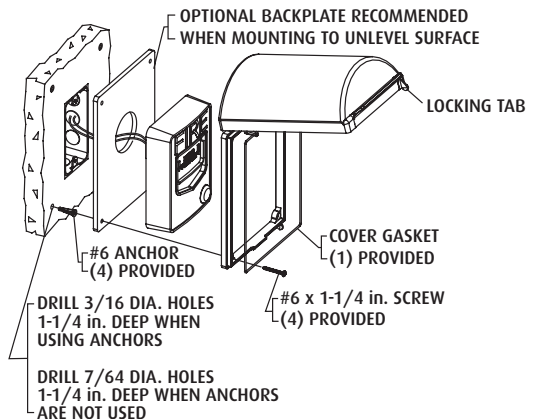

Fig. 3 - FLUSH MOUNTING OPTION

12. Make any external connections for remote power or relay options if needed. (When using HORN option refer to Fig. 5 for wiring details.) **9V battery acts as backup power source when using remote power.**
13. (For BACKBOX mounting option) Place the Device Mounting Plate STI-01310 into the raised wall area with the horn activation tab oriented sticking up in the upper left. Ensure the wire harness is not pinched underneath the plate. Use the six #6-32 x 1/2" screws to secure the Device Mounting Plate to the housing body.
14. (For BACKBOX mounting option only) Install desired powered device to the mounting screws on the Device Mounting Plate.
15. Close cover.
16. (When using LOCKING TAB feature) Not for use in fire or emergency signaling applications. With the cover closed, ensure the locking tabs are overlapping. With the cover remaining closed, drill a 1/8" hole in the center of the locking tabs.

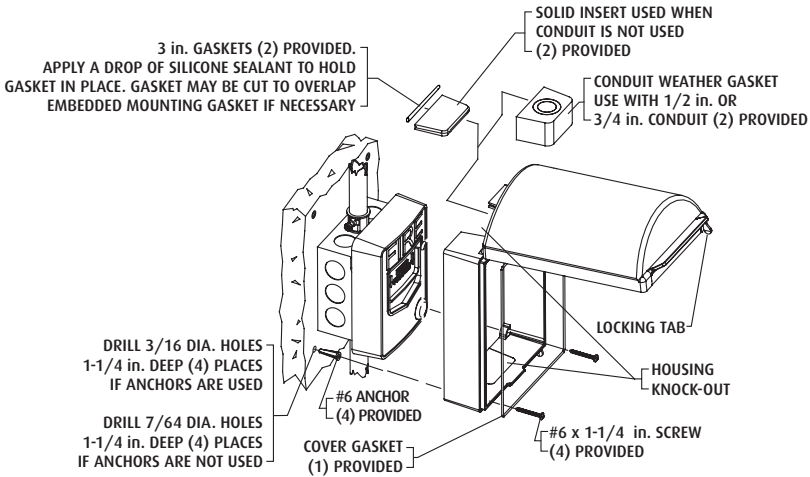
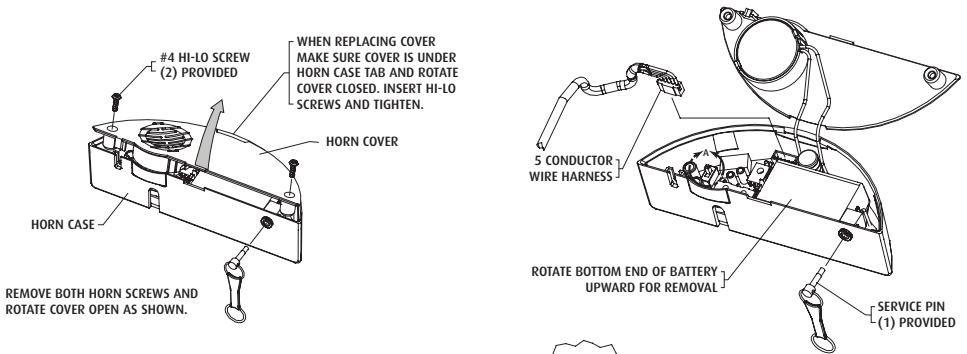
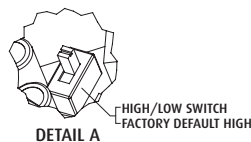

Fig. 4 - SURFACE MOUNTING OPTION



Wire	Description
Red	+12V - 24V
Black	-12V - 24V
Blue	Common
Green	NC - Norm Closed
Yellow	NO - Norm Open

Fig. 5



17. (When using HORN option) Remove the Service Pin and horn should sound. Close cover and horn should silence.
18. (When using HORN option) To test switch activation, open cover and horn should sound. Close cover and horn should silence. **When performing annual battery test/replacement or whenever servicing alarm system, insert the Service Pin into the Service Pin Receptor to prevent horn from sounding. Remember to remove Service Pin to return to normal operation.**
19. When using LOCKING TAB feature (not for use in fire or emergency signaling applications), insert the Breakaway Seal SUB-65 completely into the Locking Tab. Then insert the tip of the Breakaway Seal into the hole in the Breakaway Seal from the side that reads "ENTER." Pull the pin through until tight. Not for use with fire pull stations.

Gasket Installation:

Use of gaskets is necessary to ensure a proper seal in weatherproof applications. The Universal Stopper ships complete with all necessary gaskets and should be used accordingly. The Mounting Gasket is included on all Universal Stopper products and is embedded in the STI factory prior to shipping. Two 3" gaskets are shipped with the SURFACE mount Universal Stopper, refer to Step 8 in the installation instructions. Each 3" gasket is intended to be used with the inserts also shipped with the SURFACE mount Universal Stopper. To install, the insert should first be fitted in place in the correct orientation. Then, overlap 1/8" of the existing Mounting Gasket on the Universal Stopper housing, run the cord into the preformed channel until it overlaps 1/8" of the opposing Mounting Gasket.

Horn Battery Replacement and Hi/Lo Volume Changing Instructions:

1. Obtain the Universal Stopper Service Pin, a small Phillips screwdriver, a 3/32" allen wrench (if desired) and replacement 9V battery.
2. Open the Universal Stopper cover. The horn should sound. Insert the Service Pin into the Service Pin Receptor. The horn should silence.
3. (If desired) While holding the horn with one hand, remove the button head screw on the front of the cover. Then, perform the following actions with the horn separately.
4. Use the Phillips screwdriver to remove the two horn housing cover screws.
5. Replace the battery with a 9V battery only.
6. (If desired) Change the Hi/Lo switch position (Fig. 5, Detail A).
7. Replace the horn housing cover and screws.
8. (To be performed if horn was removed) Orient the horn at the top of the Universal Stopper cover, and replace the button head screw.
9. Remove the Service Pin and horn should sound. Close cover and horn should silence.

Polycarbonate Cleaning Instructions:

Rinse with water to remove abrasive dust and dirt. Wash with soap or mild detergent, using a soft cloth. Rinse once more then dry with a soft cloth or chamois. Exercise caution when using water inside enclosure. Make sure unit is completely dry inside before reassembling. To remove grease or wet paint from exterior of cover, rub gently with a soft cloth thoroughly wetted with Naptha. Then wash and rinse. **Do not use razor blades.**

Options Available:

Part Number	Description	Flush	Surface	Flush Enclosed Backbox	Enclosed Backbox
STI-1314	Universal Stopper Backplate	X	X		
STI-6602*	Horn Assembly	X	X		X
SUB-319	Wiring harness for remote power	X	X		X
SUB-65	Breakaway Seal (qty. 5)	X	X	X	X
EA135	Service Pin	X	X		X

*Available in red, green, blue, yellow, white or black.

Product Dimensions:

EXTERNAL DIMENSIONS:

- FLUSH 5.4 W x 8.15 H x 2.66 in. D (137 x 207 x 68 mm)
- SURFACE 5.4 W x 8.15 H x 4.00 in. D (137 x 207 x 102 mm)
- ENCLOSED FLUSH BACKBOX 5.4 W x 8.15 H x 2.8 in. D (137 x 207 x 71 mm)
- ENCLOSED BACKBOX 5.4 W x 8.15 H x 4.00 in. D (137 x 207 x 102 mm)

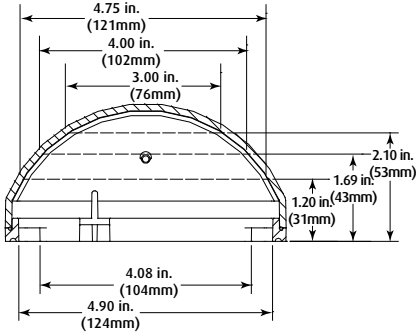

END VIEW

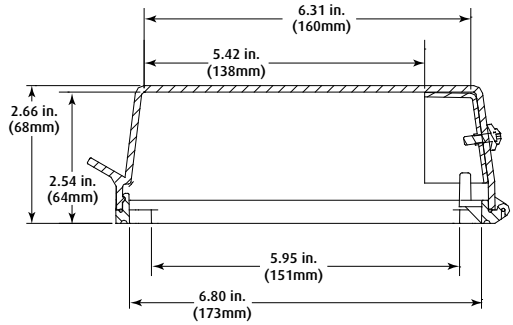

SIDE VIEW

FLUSH MOUNT DIMENSIONS

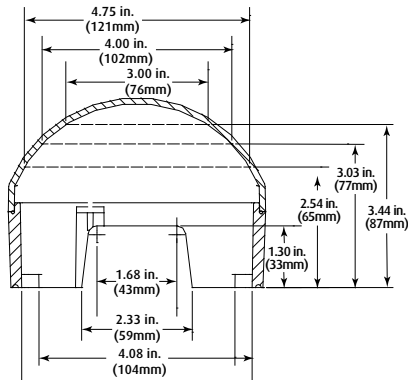

END VIEW

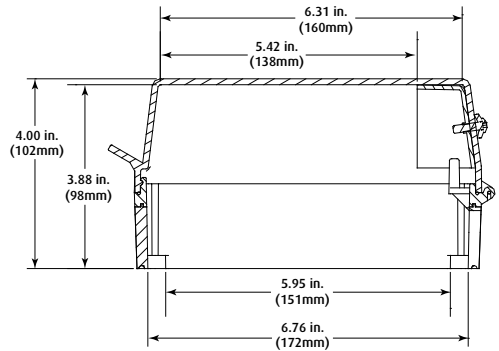

SIDE VIEW

SURFACE MOUNT DIMENSIONS

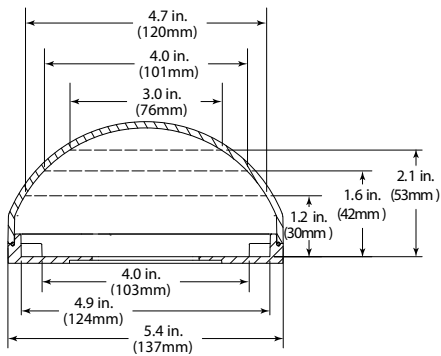

END VIEW

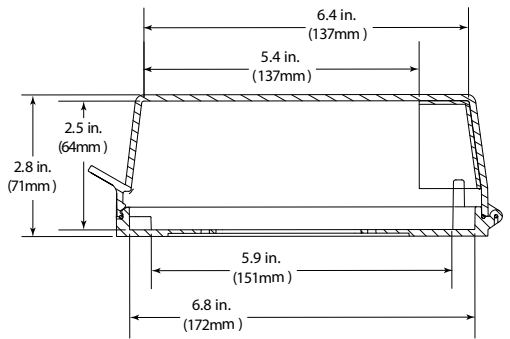

SIDE VIEW

ENCLOSED FLUSH BACKBOX DIMENSIONS

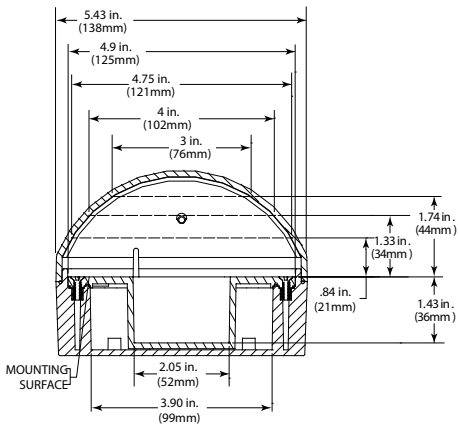

END VIEW

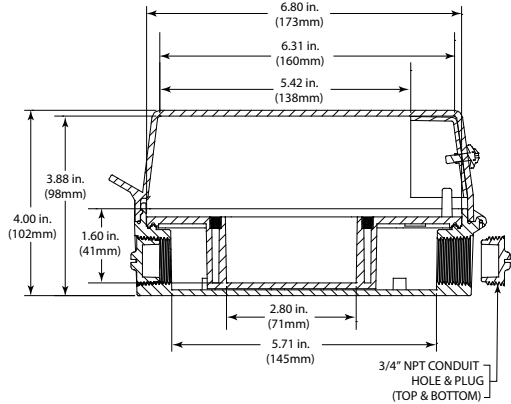

SIDE VIEW

ENCLOSED BACKBOX DIMENSIONS

Warranty

Three year guarantee against breakage of polycarbonate in normal use (one year on electro mechanical and electronic components).

Important Notice (when used on fire systems)

The Universal Stopper is intended to be used in areas where the incidence of false fire alarms from manual pull stations is high or has proven to be a serious problem. Any disadvantage of this device is more than balanced when one considers the consequences of false fire alarms, especially if fire service personnel and equipment are responding to a false fire alarm when they are needed for a real fire somewhere else. Add to this, the disruption to the facility when false alarms occur. If you have, or may have, a problem with false fire alarms or physical/weather damage to your fire alarm activation devices, the Universal Stopper could prove invaluable.